

## VARIBOX Emergency-Stop-Device NI 5061



### Your advantages

- easy to exchange due to plug connector and profile frame mounting
- slim design, easy to mount on safety guards with only one screw in profile frame

### Features

- NI 5061.06: Emergency stop with 2 NC contacts (forced opening)
- NI 5061.43: Emergency stop with 2 NC contacts (forced opening) + 1 NO contact
- M12-connection
- NI 5061.06: 4-poles
- NI 5061.43: 8-poles
- Twist release left or right
- Foolproof acc. to EN ISO 13850
- According to EN 60947-5-1, EN 60947-5-5

### Approvals and Markings



### Application

The VARIBOX emergency-stop Minibox is an electromechanical switchgear serving to protect persons working with machinery or close to it. It is used to stop or switch off machinery and equipments in order to avert impending or minimise existing dangers to persons or damages on machines /material.

The following (inter)national statutory provisions apply to installation, commissioning and regular technical inspections:

- Directive 2006/42/EG
- Low-Voltage Directive 2006/95/EG
- Safety Regulations as well as
- Regulations of the Accident Prevention / Safety Rules

Manufacturers and operators of machines using E-stops or emergency switch-off devices should retain the responsibility for the adherence of these instructions as well as for compliance with the relevant Safety Regulations and Rules

For the application of E-stops /emergency switch-off devices as directed the respective requirements for installation and operation must be observed:

- EN60204-1:2006
- EN13849-1/-2:2008
- EN ISO 13850:2008

### Function

The VARIBOX has been designed for M12-connection. The button is actuated by pushing and reset by turning into both directions.

### Standard Type

VARIBOX Not-Halt-Gerät NI 5061.06  
Article number: 0065346

### Variant

VARIBOX Not-Halt-Gerät NI 5061.43  
8-poles; 2 NC contacts (forced opening) + 1 NO contact  
Article number: 0065694

### Technical Data

Contacts	4-poles 2 NC contacts (forced opening)	8-poles 2 NC cont. (forced opening) + 1 NO cont.		
<b>Thermal current <math>I_{th}</math>:</b> AC 15 at 40 °C: DC 13:	4 A 2.5 A			
<b>Switching capacity</b>	to AC 15: IEC/EN 60 947-5-1 1.5 A / AC 240 V 3 A / AC 120 V	1 V ... 36 V		
	to DC 13: 0.27 A / DC 250 V 0.55 A / DC 125 V 1 A / DC 60 V 2 A / DC 24 V	1 mA ... 250 mA		
<b>Electrical life:</b>	50.000 at rated load			
<b>Mechanical life:</b>	50.000 operations (ambient temperature = 20 °C)			
<b>Bouncing time:</b>	< 10 ms			
<b>Forcible NC:</b>	acc. to EN 60947-5-1, appendix K			
<b>Force opening distance:</b>	> 3 mm			
<b>Overtoltage category:</b>	II			
<b>Test voltage</b>	2.0 kV			
<b>M12-plug:</b>	AgNi			
<b>Contact material:</b>	AgNi	AgNi, gold plated 5 µm		
<b>Temperature range</b>	Operation: - 25 ... + 70 °C Storage: - 25 ... + 85 °C			
<b>Altitude:</b>	< 2.000 m			
<b>Degree of protection:</b>	IP 65			
<b>Connection:</b>	M12; 4-poles (m)	M12; 8-poles (m)		
	Pin	Description	Pin	Description
	1	NC contact 1	1	NC contact 1
	2		2	NC contact 1
	3	NC contact 2	3	NC contact 2
	4		4	NC contact 2
			5	NO contact
			6	
			7	
			8	n. c.
<b>Fixation:</b>	with fastening clip			

**VARIBOX**  
Emergency-Stop-Device  
NI 5061

Original



**DANGER**

- Dangerous voltage.**
- Electric shock will result in death or serious injury.**
- Disconnect all power supplies before servicing equipment.

**CAUTION**

**Safe operation of the device is only guaranteed when using certified components!**

**Safety notes**

The product hereby described was developed to perform safety functions as a part of a whole installation or machine. A complete safety system normally includes sensors, evaluation units, signals and logical modules for safe disconnections. The manufacturer of the installation or machine is responsible for ensuring proper functioning of the whole system. DOLD cannot guarantee all the specifications of an installation or machine that was not designed by DOLD. The total concept of the control system into which the device is integrated must be validated by the user. DOLD also takes over no liability for recommendations which are given or implied in the following description. The following description implies no modification of the general DOLD terms of delivery, warranty or liability claims.

**ATTENTION**

- This device must be installed and operated by trained staff who are familiar with these instructions and with the current regulations for safety at work and accident prevention.
- Pay attention to applicable local regulations, especially regarding safety measures.
- E-stops/ emergency switch-off devices fulfil the function of personal protection. Improper installation or unauthorised modification may lead to severe personal injuries
- E-stops /emergency switch-off devices should not be bypassed, removed or otherwise disabled
- Improper installation or tampering may result in machine and material damages!
- The E-stop /emergency switch-off function should not replace the applicable safety precautions or other safety functions but should rather be used as a back-up safeguarding measure
- The E-stop /emergency switch-off function should not impair the effectiveness of other safety devices or equipment with other safety functions.
- Based on his hazard analysis the design engineer must ensure that in combination with the control system the E-stop /emergency switch-off device meets the required safety category

**Dimension [mm]**

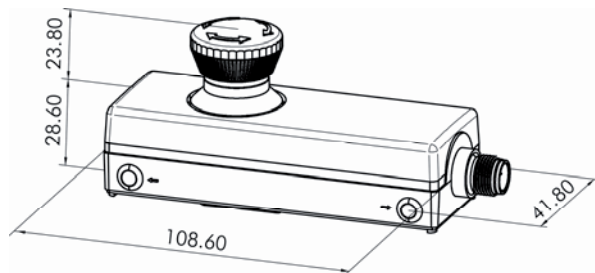

**Assembly and Commissioning**

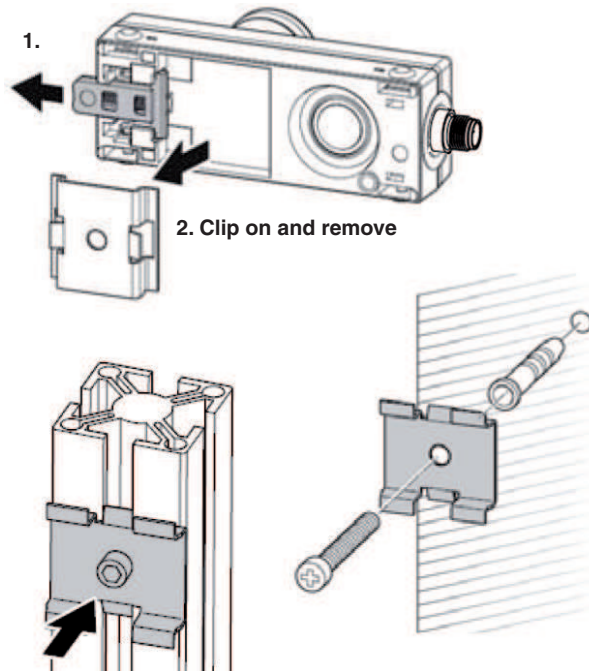

Mounting on profile

Wall mounting

**Testing Before First Operation**

- Mechanical Test: E-stop/switch-off device latches when operated
- Electrical Test: Machine stops / switches off

**Disassembling**

Before disassembling disconnect equipment and device from the mains!!

**Note**

- A „click“ must be heard when closing the box
- Check whether the two Minibox parts are snapped together properly.
- Make sure that the E-stop is always easily accessible.

**Maintenance**

- Based on his risk assessment, the machine designer has to determine the inspection interval. It is, however, recommended that the competent safety officer activates and tests the E-stop or switch-off device at least once a year to ensure its proper functioning.
- Mechanical and electrical functional testing acc. to paragraph 4
- Secure mounting
- No visible unauthorised modifications or damages
- No loose connections

**Incident Management**

Mechanical overload or external impact damage may impair the function of the E-stop / switch-off device. Make functional tests as mentioned under „Maintenance“.